

# PORTABLE GASOLINE GENERATOR

## SIERRA 5500

### WARNING:

Read this manual before operating generator. Failure to follow all safety precautions could result in death, personal injury, or property damage.

Save this manual for future reference.



# OWNER'S MANUAL

Thank you for purchasing a GMC Portable Gasoline Generator.

Record the model and serial number as indicated on your generator's nameplate:

MODEL No. \_\_\_\_\_

Serial No. \_\_\_\_\_

Date of Purchase: \_\_\_\_\_

Store/Dealer purchased from: \_\_\_\_\_

### HOW TO FIND A LOCAL SERVICE CENTER

Even quality built equipment such as the GMC Portable Gasoline Generator you purchased, might need service or repair parts. Either call the GMC Generator Service Department at 1-866-409-4581 or go to [www.GMCGENERATORS.com](http://www.GMCGENERATORS.com).

Please provide the information below

1. Model No. and Serial No. and all specifications shown on the Model No. /Serial No. plate.
2. Part number or numbers as shown in the Parts List section of the manual for your generator model.
3. A brief description of the trouble with the generator.

Service Department at 1-866-409-4581

visit [www.GMCGENERATORS.com](http://www.GMCGENERATORS.com)

**Note:** If replacement parts are required for the engine, contact the engine, manufacturer's service centers.

Do not return your generator for service or parts to the store/dealer where purchased or any GMC or GM car/truck dealership.

### GMC PORTABLE GASOLINE GENERATOR

Model number	<input type="text"/>	Phase	<input type="text"/>
Part Number	<input type="text"/>	Frequency	<input type="text"/>
AC Voltage	<input type="text"/>	Engine RPM	<input type="text"/>
Power Output	<input type="text"/>	Fuel	<input type="text"/>
Serial Number	<input type="text"/>		

The GMC Trademark is used under the license from General Motors Corporation. GMC or General Motors Corporation makes no representation or warranties with respect to this product.

# Product Registration

To register your product, please complete the information below and mail to the mailing address at the end of this form or register online at [www.GMCGENERATORS.com](http://www.GMCGENERATORS.com)

## 1. Personal Information:

First Name: \_\_\_\_\_ Initial: \_\_\_\_\_ Last Name: \_\_\_\_\_

Mailing Address: \_\_\_\_\_

City: \_\_\_\_\_ State: \_\_\_\_\_ Zip Code: \_\_\_\_\_

Phone Number: \_\_\_\_\_

Email Address: \_\_\_\_\_

(Check here to receive product information and offers via email)

(Check here to receive product information from other companies via email)

## 2. Product Information:

Date of Purchase: \_\_\_\_\_ MM/ \_\_\_\_\_ DD/ \_\_\_\_\_ YYYY

Model Number: \_\_\_\_\_

Serial Number: \_\_\_\_\_ (Found on nameplate on generator)

Purchased Location: \_\_\_\_\_

Purchase Price: \_\_\_\_\_

Type of Primary Use for this Product: \_\_\_\_\_

Home , Recreation ,Emergency , Rental, Commercial:

Features Influencing Product Purchase: \_\_\_\_\_

Brand, Portability, Power Rating ,Price ,Warranty , Other Features (describe)

What other Power Equipment are you interested in purchasing in the future? \_\_\_\_\_

Thank you for registering your product.

(check here to receive product information and special offers)

Mail to:

California Air Tools  
675 Anita Street C3  
Chula Vista Ca. 91911

# Table Of Contents

<b>Introduction</b> _____	<b>4</b>
<b>Important Safety Rules</b> _____	<b>5</b>
<b>Important Safety instructions</b> _____	<b>6-12</b>
<b>Control Panel and Generator Components</b> _____	<b>13-14</b>
<b>Assemble</b> _____	<b>15</b>
<b>Operating the Generator</b> _____	<b>16-26</b>
<b>Maintenance</b> _____	<b>27-34</b>
<b>Storage</b> _____	<b>35</b>
<b>Troubleshooting</b> _____	<b>36</b>
<b>Specifications</b> _____	<b>37</b>
<b>Warranty</b> _____	<b>38-40</b>

# PORTABLE GASOLINE GENERATOR

**SIERRA 5500**

## Introduction

Thank you for purchasing a GMC Portable Gasoline Generator. This manual details the parts, assembly, operation, maintenance, troubleshooting, storage, and warranty of the equipment. Your generator is intended for **OUTDOOR USE ONLY**.

Your GMC Generator is designed to provide a portable source of electricity in temporary or remote applications, including emergency situations.

Please retain this manual for future reference. Important safety instructions and warnings are contained.

Please do not hesitate to contact us.

Service Department at 1-866-409-4581

visit [www.GMCGENERATORS.com](http://www.GMCGENERATORS.com)

This manual has been prepared to provide you with accurate and complete information about your generator. We reserve the right to modify this document and/or the design of the product without prior notice.

Your generator meets the emission requirements of EPA guidelines.



## Safety Messages

### Signal Words

#### **DANGER**

Indicates an immediate hazardous situation which, if not avoided, will result in death or serious injury to the operator or to bystanders.

#### **WARNING**



Indicates a potentially hazardous situation which, if not avoided, could result in death or serious injury to the operator or to bystanders.

#### **CAUTION**

Indicates a potentially hazardous situation which, if not avoided, may result in moderate or minor injury to the operator or to bystanders.

#### **NOTICE**

Indicates a situation which, if not avoided, may result in damage to generator components.

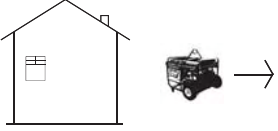
 <b>DANGER</b>	
<b>Using a generator indoors CAN KILL YOU IN MINUTES.</b>	
Generator exhaust contain carbon monoxide. This is a poison you cannot see or smell.	
	
<b>NEVER</b> use inside a home or garage, <b>EVEN IF</b> doors and windows are open.	<b>Only use OUTSIDE</b> and far away from windows, doors, and vents
<b>Avoid other generator hazards READ MANUAL BEFORE USE</b>	

#### **WARNING**

##### CALIFORNIA PROPOSITION 65 WARNING:

Engine exhaust from this product contains chemicals known to the state of California to cause cancer, birth defects and other reproductive harm.

# Important Safety Rules

## Hazard Symbols and Meanings

In addition to the signal words described above, the following symbols may be used to draw your attention to specific types of hazards.



FIRE



EXPLOSION



KICKBACK



HOT SURFACE



SHOCK

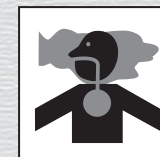

TOXIC FUMES

# PORTABLE GASOLINE GENERATOR

**SIERRA 5500**

## **! DANGER**

Read this manual before operating generator. Failure to follow all safety precautions could result in death, personal injury, or property damage.



TOXIC FUME

## **! WARNING**

**WARNING** Engine exhaust contains chemicals known to the State of California to cause cancer, birth defects, or other reproductive harm.

## **! WARNING**

Generator surfaces become hot during operation.

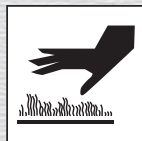

HOT SURFACE



FIRE

# Important Safety Instructions

## Save These Instructions

## **! DANGER**

Failure to follow these instructions and warning may result in death personal injury, or property damage.

1. Generator exhaust contains carbon monoxide (CO).
2. This is a poison you cannot see or smell. If you can smell the generator exhaust, you are breathing (CO). But even if you cannot smell the exhaust, you could be breathing (CO).
3. **NEVER** use a generator inside homes, garages, crawlspaces, or other partly enclosed areas.
4. Deadly levels of carbon monoxide can build up in these areas. Using a fan or opening windows and doors does **NOT** supply enough fresh air.
5. **ONLY** use a generator outside and far away from windows, doors, and vents. These openings can pull in generator exhaust.
6. Even when you use a generator correctly, (CO) may leak into the home.
7. **ALWAYS** use a battery-powered or battery backup (CO) alarm in the home.
8. If you start to feel sick, dizzy, or weak after the generator has been running, move to fresh air **RIGHT AWAY**. See a doctor. You could have carbon monoxide poisoning.

## **! WARNING**

9. Hot surfaces can cause severe burns.
10. **DO NOT** touch hot surfaces.
11. Avoid hot exhaust.
12. Ensure that exhaust vent is not obstructed.
13. Allow the generator to cool before touching.
14. Generator could ignite nearby materials.
15. Maintain at least five feet of clearance around the generator; this includes space above the generator.
16. **DO NOT** place a storage cover on the unit during operation. Only place a cover on the generator after it has thoroughly cooled down.

# **WARNING**

- 17. Only check for a spark with an approved spark plug tester.
- 18. **DO NOT** check for a spark with the spark plug removed.
- 19. Disconnect spark plug wire when servicing the generator.

- 20. Keep hands and feet away from rotating parts, tie up long hair, remove jewelry, and **DO NOT** wear loose clothing.

- 21. Use only undamaged electrical cords.
- 22. **DO NOT** touch bare wires or receptacles.
- 23. **DO NOT** operate generator in wet weather or in wet conditions.
- 24. **DO NOT** contact generator or cords if hands or feet are wet.  
Your generator is equipped with a ground fault circuit interrupter (GFCI) and should always be used.
- 25. Use only approved transfer equipment to attach generator to your power system. Only a qualified electrician should install this.
- 26. **DO NOT** plug your generator directly into house or garage sockets, (a practice known as backfeeding). This can result in death or serious injury to electric utility workers.

### *Always ground the generator.*

- 27. The faceplate of your generator is marked with the following grounding symbol above the grounding terminal:



- 28. Attach a heavy gauge copper wire (12 AWG minimum) to this terminal and link it to a copper rod driven into the ground. Consult an electrician to ensure compliance with local codes and regulations.



SHOCK



FIRE



KICKBACK



SHOCK



EXPLOSION



FIRE

## **WARNING**

Sparks can result in fire or electrical shock

## **DANGER**

Moving parts can cause severe trauma

## **DANGER**

Generator Voltage is Deadly. There is a danger of electric shock.

## **CAUTION**

**DO NOT** exceed generator's capacity.

# **WARNING**



EXPLOSION



SHOCK



FIRE

- 29. Overloading can damage the generator and the electrical equipment connected to it. After starting the generator, allow the motor to stabilize.
- 30. Connect devices in their OFF position one at a time.
- 31. Before turning the generator off, turn off the devices and disconnect them from the generator.

## **DANGER**

Gasoline and gasoline vapors are highly flammable and explosive



EXPLOSION



FIRE

- 32. Turn generator OFF while refueling.
- 33. Wait several minutes before opening the fuel tank to allow the generator to cool down.
- 34. Only refuel generator outdoors in a well-lit and well-ventilated area.
- 35. If any fuel is spilled, allow it to evaporate before starting the generator.
- 35. **DO NOT** overfill the fuel tank.
- 36. **DO NOT** smoke or use open flame near the generator.

## **CAUTION**

Engine oil must be added prior to starting generator, and proper oil level must be maintained



OIL

Failure to add or maintain proper oil level voids your warranty.

If generator is not level, it could shut off, suffer decreased performance, and damage property. Failure to add or maintain proper oil level voids your warranty

## **WARNING**

Generator must be placed on a firm, level surface.

## **WARNING**

Keep children and pets away from the generator.

Generators vibrate during normal use. During and after the use of the generator, inspect the generator as well as extension cords and connected power supply cords for damage resulting from vibration. Repair or replace damaged items as necessary. DO NOT use plugs or cords that show signs of damage such as broken or cracked insulation or loose or damaged blades.

## WARNING

When this generator is used to supply a building wiring system:

Generator must be installed by a qualified electrician and connected to a transfer switch as a separately derived system in accordance with the National Electrical Code, NFPA 70.

The generator shall be connected through a transfer switch that switches all conductors other than the equipment grounding conductor.

The frame of the generator shall be connected to an approved grounding electrode.



SHOCK



KICKBACK

## WARNING

Always inspect fuel lines and electrical connections for defects and damage prior to operating the generator.

## WARNING

Starter cord can retract rapidly and cause injury.



FIRE

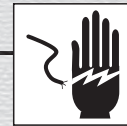

SHOCK



EXPLOSION

# PORTABLE GASOLINE GENERATOR

**SIERRA 5500**

## **CAUTION**

CAUTION: FOR STANDBY SERVICE, CONNECT OUTPUT OF GENERATOR TO SUITABLY RATED TRANSFER SWITCH IN ACCORDANCE WITH THE CANADIAN ELECTRICAL CODE, PART I.

## **WARNING**

DO NOT place or store any items on the generator.

## **WARNING**

DO NOT place or store any items on the generator.

## **WARNING**

DO NOT operate generator if you are fatigued or under the influence of alcohol or drugs.

# For CANADA

## Save These Instructions

Empty the fuel tank before transporting generator. Make sure that the fuel switch is turned OFF. Disconnect the spark plug wire before transporting generator.

Injury and property damage can occur if generator is used improperly.  
DO NOT tamper with speed governor.  
DO NOT operate the generator in wet weather or in wet conditions.  
DO NOT expose the generator to excessive dust or dirt.  
Ensure that exhaust vent is not obstructed.  
Improper usage of the generator voids your warranty.

For power outages, permanently installed stationary generators are better suited for providing backup power to the home. Even a properly connected portable generator can become overloaded, which can result in overheating or stressing of the generator components. This can lead to generator overheating, failure, or fire.

Consult a qualified electrician if you have questions regarding the proper use of the generator, including any electrical devices to be connected.

**! CAUTION**

Wheels are not intended for over the road use.

**! WARNING**

Transport the generator safely.

**! WARNING**

Never operate a damaged or defective generator.

**! CAUTION**

Do not spray generator with water or a garden hose.

**! CAUTION**

Only operate the generator as intended

# Pre-Operation Check list

## Engine Oil Recommendations

SAE 10W-30 standard motor oil is recommended for normal operating conditions and temperatures (between 0 and 100 degrees Fahrenheit)

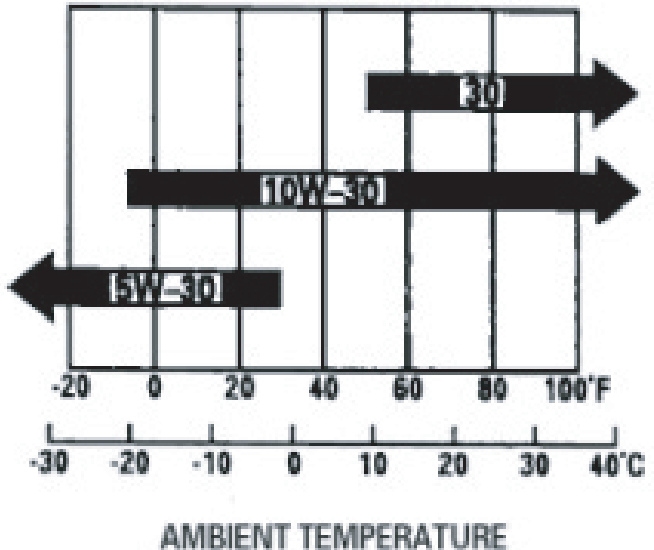

# Checking Oil level

1. Have your generator on a flat, level surface.  
**Note:** Stop generator from running. Allow to completely cool.



HOT SURFACE

2. Remove the oil filter cap and wipe the dipstick clean with a clean cloth.
3. Check the oil level by inserting the dipstick in the filter neck without screwing it in. If the level is below the lower level line, add the recommended oil until the level reaches the upper mark on the dipstick.
4. Oil capacity to the upper level line 1.1 (L), 1.2 (qt)
5. Refer to the Maintenance Schedule (page 29) for regular service intervals.

**Note:** The oil alarm light will come on if the oil level falls below the recommended safety level. Regular inspection (before each use) of the oil level is recommended to prevent the engine from shutting down unexpectedly and damage occurring. Refer to the Maintenance section for more information.

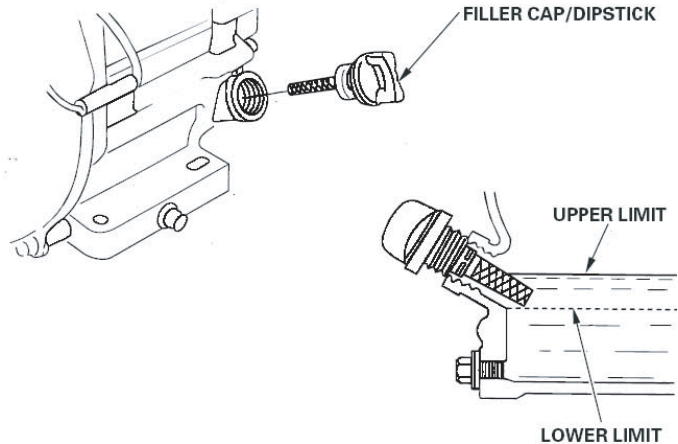

# PORTABLE GASOLINE GENERATOR

## SIERRA 5500

Read these important labels before operating

These labels provide important safety and maintenance information.

These labels should be considered as permanent parts of the generator. Should any of these labels become illegible, damaged or removed please contact Customer Service at Customer Support 1-866-409-4581 for replacements

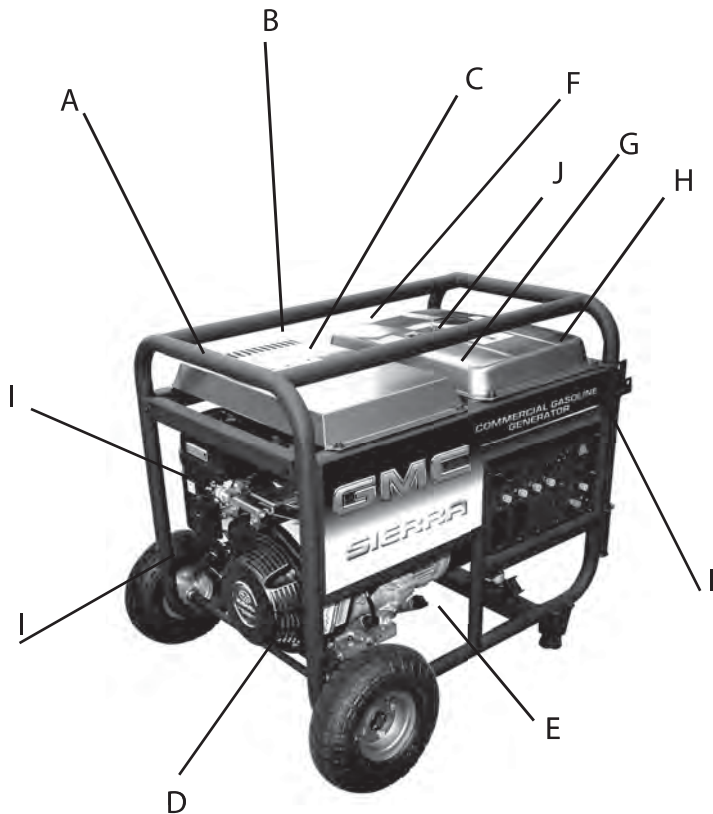

# LOCATION OF IMPORTANT LABELS

	PRODUCT LABEL	PART NUMBER
A		GMCS01
B		GMCS02
C		GMCS03
D		GMCS04
E		GMCS05
F		GMCS06
G		GMCS07
H		GMCS09
I		GMCS10
J		GMCS11

# PORTABLE GASOLINE GENERATOR

**SIERRA 5500**

Portable Gasoline Generator  
SIERRA 5500

## CONTROL PANEL

V.F.T. Meter (Voltage/Frequency/Time)  
Voltage Selector  
Auto Throttle  
Circuit Breaker  
Engine Switch  
Low Oil Light  
DC 12V  
Ground  
AC 120V/240V  
AC 120V(G.F.C.I.)  
AC Circuit Protectors

## GENERATOR COMPONENTS

Handles  
Control Panel  
Wheels  
Oil Cap/Dipstick  
Engine  
Stand  
Fuel Tank  
Sky Hook  
Fuel Gauge  
Recoil Starter Grip  
Air Filter  
Fuel Valve  
Choke Lever

# CONTROL PANEL AND GENERATOR COMPONENTS

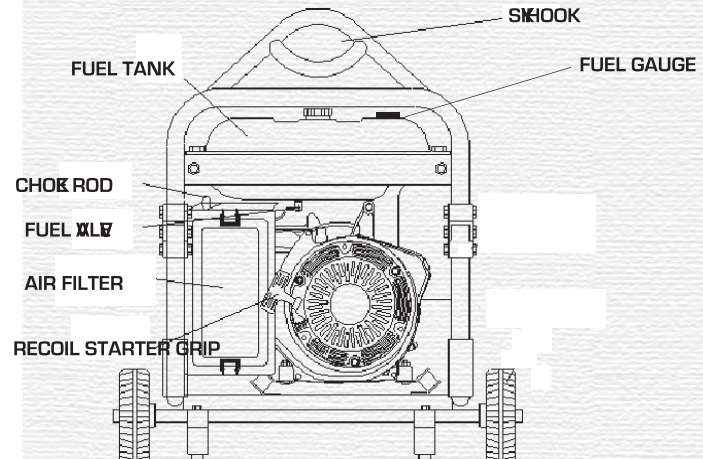
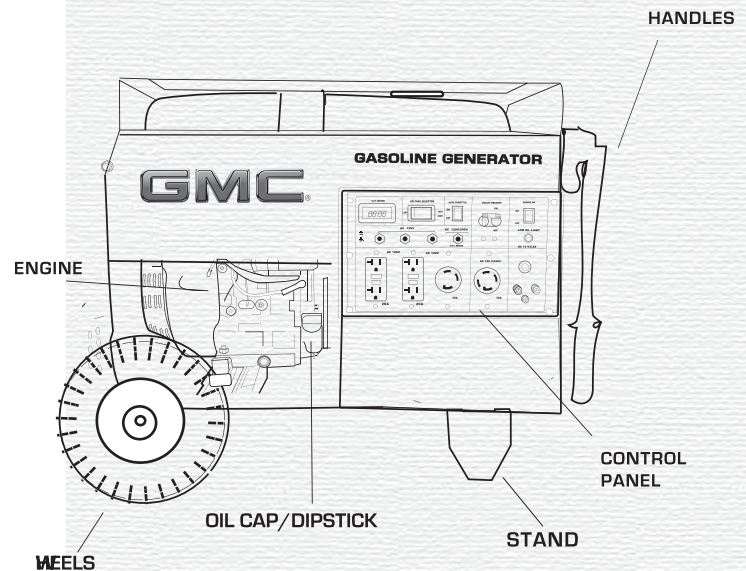
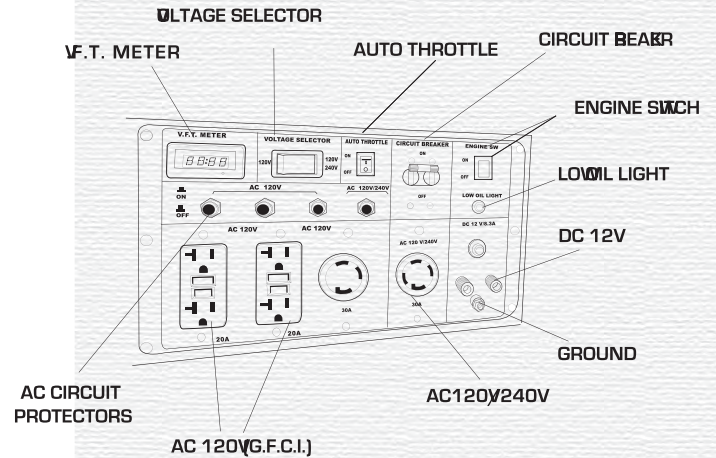

# Pre-Operation Check list

## Fuel

This engine is designed to use unleaded gasoline with a octane number of 87 or higher to run properly.

Leaded gasoline or lower octane gasolines are not recommended and can cause unusual wear on the exhaust system and spark plugs.

Never use dirty, stale/old or any gasoline with water or oil added to it. This will cause harm to the engine.

**Note:** Occasional, light spark knock, "pinging", or metal tapping noises are normal while operating under heavy loads. If "pinging" or "knocking" or loud metal tapping occurs during steady engine speeds under normal load, shut off the engine and replace fuel with fresh gasoline. If these noises persists go to an authorized GMC Generator Service Center.

## Gasoline Containing Alcohol

Oxygenated fuel is blended with alcohol or other additives to increase octane quality, enhance combustion, and reduce exhaust emissions. If you use oxygenated fuel it must have a octane of 87 or higher as recommended above. Gasoline containing more than 10% Ethanol (Gasohol) is not recommended. Gasoline containing 5% or less of Methanol must contain co-solvents and corrosion inhibitors to protect the fuel system. Never use gasoline with more than 5% Methanol.

**Note:** Fuel system damage or engine performance problems resulting from the use of fuels that contain alcohol is not covered under the warranty.

## Adding Fuel

1. Have your generator on a flat, level surface.  
**Note:** Stop generator from running. Allow to completely cool.
2. Check fuel tank gauge. Add fuel if the level is low.  
**Note :** Never overfill or fill above the fuel filter shoulder
3. Remove the fuel cap and filter. Clean filter and replace. Fill tank. Do not over fill.
4. After refueling replace the fuel tank cap tightly.
5. Fuel tank capacity is 7Gallons ( 26.5Liters)

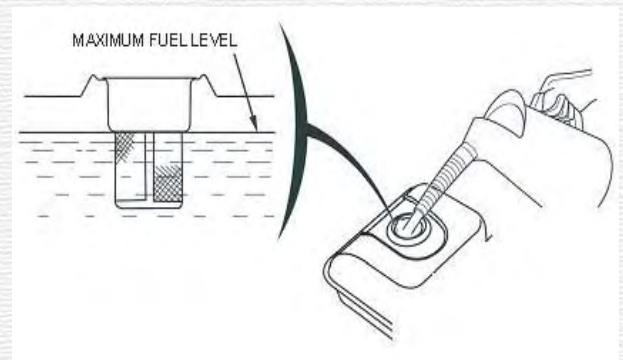
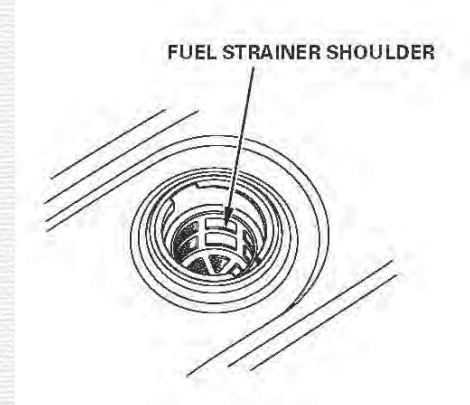

FIRE



EXPLOSION



HOT SURFACE



TOXIC FUME

# PORTABLE GASOLINE GENERATOR

**SIERRA 5500**

## Oil Alarm

1. The Oil Alarm system is designed to prevent the engine from being damaged because of the lack of oil in the crankcase. Before the oil level falls to an unsafe level the Oil Alarm light will come on and the engine will shut off. Although the engine is automatically shut off the engine switch will still remain in the ON position.
2. If the Oil Alarm light comes on, turn off the generator immediately and fill the engine with oil. Refer to the Maintenance Schedule (page 29) and the Engine Oil section (page 16).

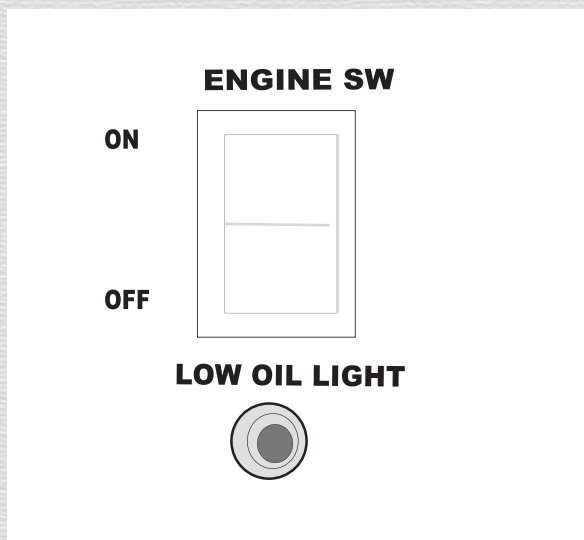

## V.F.T. Digital Meter Display

1. V.F.T. digital meter displays the running voltage, the running frequency and both the current time of use and the continuous time of use for maintenance purposes.

### V.F.T. METER

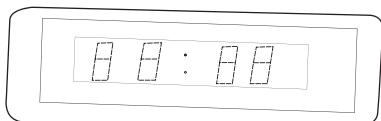

## Circuit Breaker

1. The circuit breaker protects the individual circuit protectors and the 50A 120/240V receptacle. The circuit breaker will automatically switch OFF if the circuit is overloaded or the appliance plugged into the circuit is faulty. If the circuit breaker is switched OFF automatically, check that the appliance is working properly and that it does not exceed the rated load capacity of the circuit before switching the circuit breaker ON again.

### CIRCUIT BREAKER

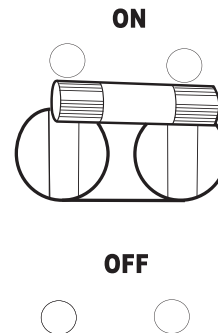

## Circuit Protector

1. The circuit protectors will automatically switch OFF if the individual circuit is overloaded or the appliance plugged into the circuit is faulty. If the circuit protector is switched OFF automatically, check that the appliance is working properly and that it does not exceed the rated load capacity of the circuit before resetting the circuit protector by pressing the reset buttons.

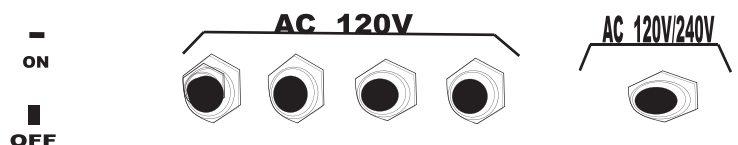

# PORTABLE GASOLINE GENERATOR

**SIERRA 5500**

## Oil Alarm

- 1.** The Oil Alarm system is designed to prevent the engine from being damaged because of the lack of oil in the crankcase. Before the oil level falls to an unsafe level the Oil Alarm light will come on and the engine will shut off. Although the engine is automatically shut off the engine switch will still remain in the ON position.
- 2.** If the Oil Alarm light comes on, turn off the generator immediately and fill the engine with oil. Refer to the Maintenance Schedule (page 29) and the Engine Oil section (page 16).

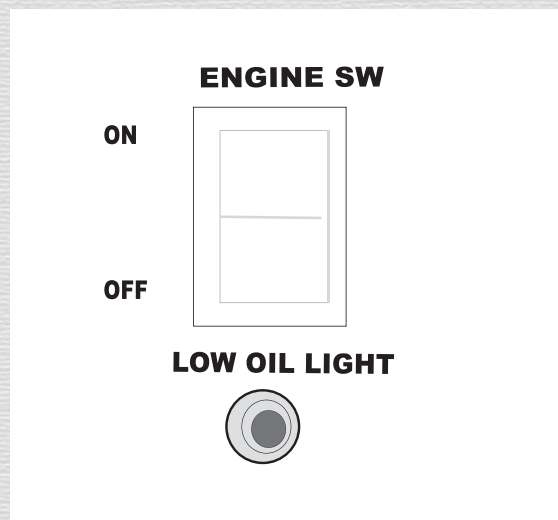

## V.F.T. Digital Meter Display

- 1.** V.F.T. digital meter displays the running voltage, the running frequency and both the current time of

# ENGINE SW

**ON**

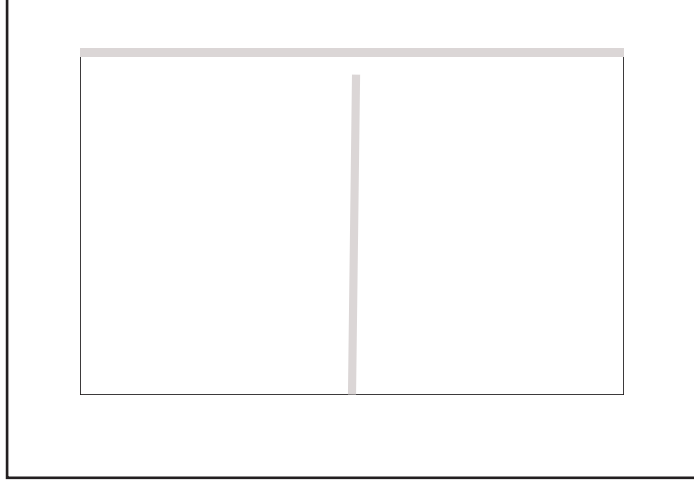

**OFF**

# LOW OIL LIGHT

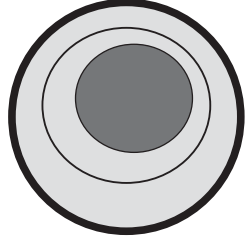

# PORTABLE GASOLINE GENERATOR

**SIERRA 5500**

## Oil Alarm

- 1.** The Oil Alarm system is designed to prevent the engine from being damaged because of the lack of oil in the crankcase. Before the oil level falls to an unsafe level the Oil Alarm light will come on and the engine will shut off. Although the engine is automatically shut off the engine switch will still remain in the ON position.
- 2.** If the Oil Alarm light comes on, turn off the generator immediately and fill the engine with oil. Refer to the Maintenance Schedule (page 29) and the Engine Oil section (page 16).

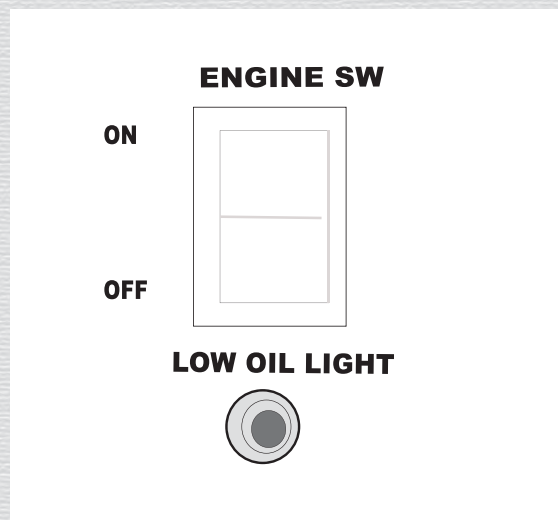

## V.F.T. Digital Meter Display

- 1.** V.F.T. digital meter displays the running voltage, the running frequency and both the current time of

# PORTABLE GASOLINE GENERATOR

**SIERRA 5500**

## Oil Alarm

- 1.** The Oil Alarm system is designed to prevent the engine from being damaged because of the lack of oil in the crankcase. Before the oil level falls to an unsafe level the Oil Alarm light will come on and the engine will shut off. Although the engine is automatically shut off the engine switch will still remain in the ON position.
- 2.** If the Oil Alarm light comes on, turn off the generator immediately and fill the engine with oil. Refer to the Maintenance Schedule (page 29) and the Engine Oil section (page 16).

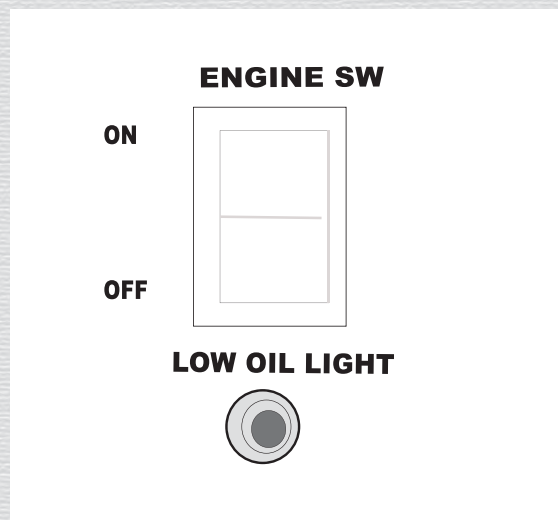

## V.F.T. Digital Meter Display

- 1.** V.F.T. digital meter displays the running voltage, the running frequency and both the current time of

# PORTABLE GASOLINE GENERATOR

**SIERRA 5500**

## Oil Alarm

- 1.** The Oil Alarm system is designed to prevent the engine from being damaged because of the lack of oil in the crankcase. Before the oil level falls to an unsafe level the Oil Alarm light will come on and the engine will shut off. Although the engine is automatically shut off the engine switch will still remain in the ON position.
- 2.** If the Oil Alarm light comes on, turn off the generator immediately and fill the engine with oil. Refer to the Maintenance Schedule (page 29) and the Engine Oil section (page 16).

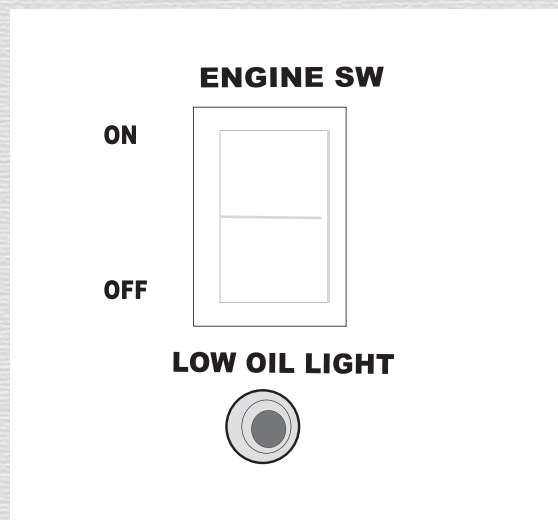

## V.F.T. Digital Meter Display

- 1.** V.F.T. digital meter displays the running voltage, the running frequency and both the current time of

# Circuit Protector

1. The circuit protectors will automatically switch OFF if the individual circuit is overloaded or the appliance plugged into the circuit is faulty. If the circuit protector is switched OFF automatically, check that the appliance is working properly and that it does not exceed the rated load capacity of the circuit before resetting the circuit protector by pressing the reset buttons.

**AC 120V**

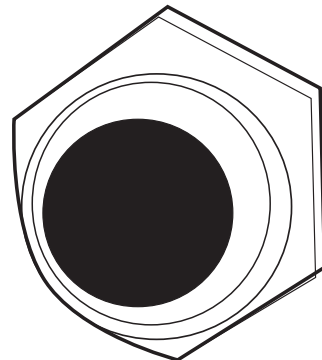
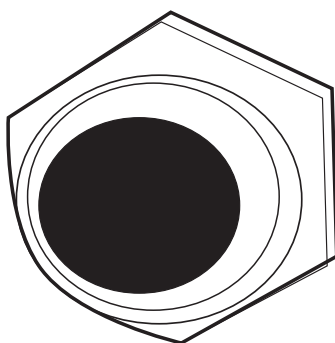
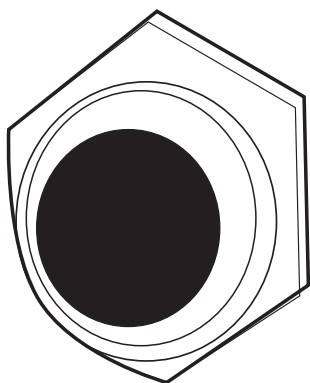

# V.F.T. Digital Meter Display

1. V.F.T. digital meter displays the running voltage, the running frequency and both the current time of use and the continuous time of use for maintenance purposes.

## V.F.T. METER

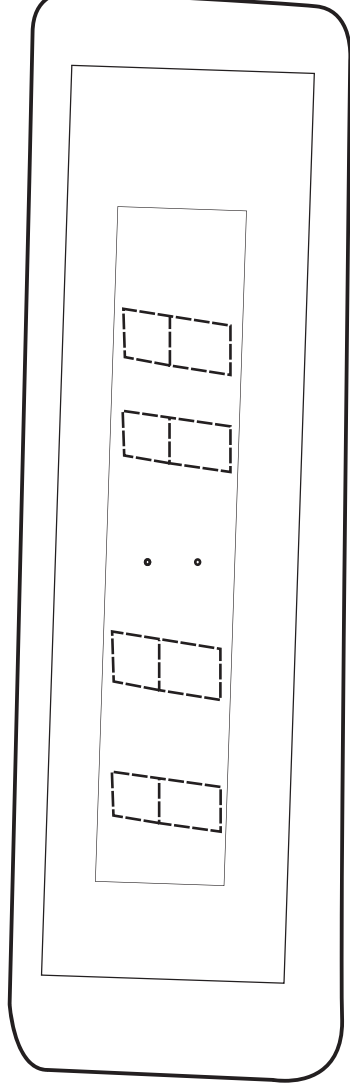

# Sky Hook Installation

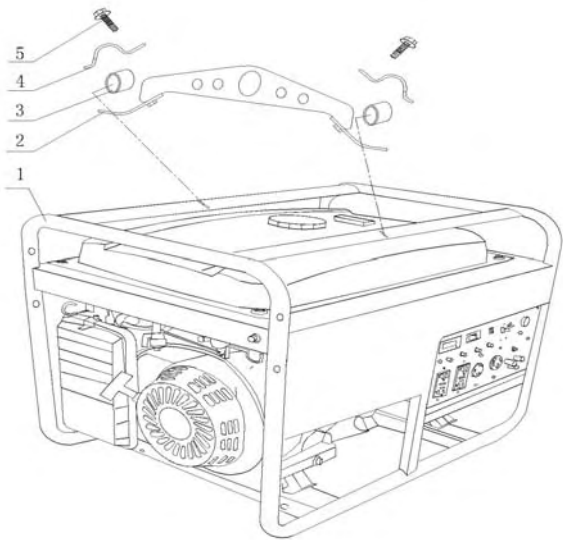
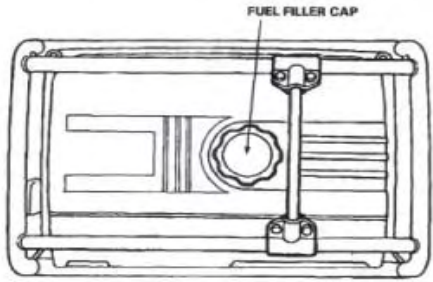

1. Put the two rubber sleeves(3) on the marked locations on the generator frame.
2. Mount the holding plates(4), skyhook assemble (2) on the frame with the four bolts M8x20(5) and tighten.

1-Generator, 2-Skyhook assemble(1), 3-Rubber Sleeve(2).  
4-Holding plate(2), 5-Bolt M8x20(4)

**Note:** The Sky Hook is limited to the weight of the generator (293 pounds) any added weight will cause damage and void warranty and liability.

# Wheel & Handle Kit Installation

1. Assemble the two wheels(5) on the axle(4), then attach them with the two washers (8) and two split pins(9)
2. Mount assembled axle (4) to the frame with axle holder(10), bolt(6)and nut (7). Refer to diagram# 1
3. Fit the two stands(11) on the frame with the two bolts(6) and nuts(7)
4. Fit the two handles(13) on the connecting block (12) with the two bolts(15) and nuts(7), then mount the assembled handle on the frame.

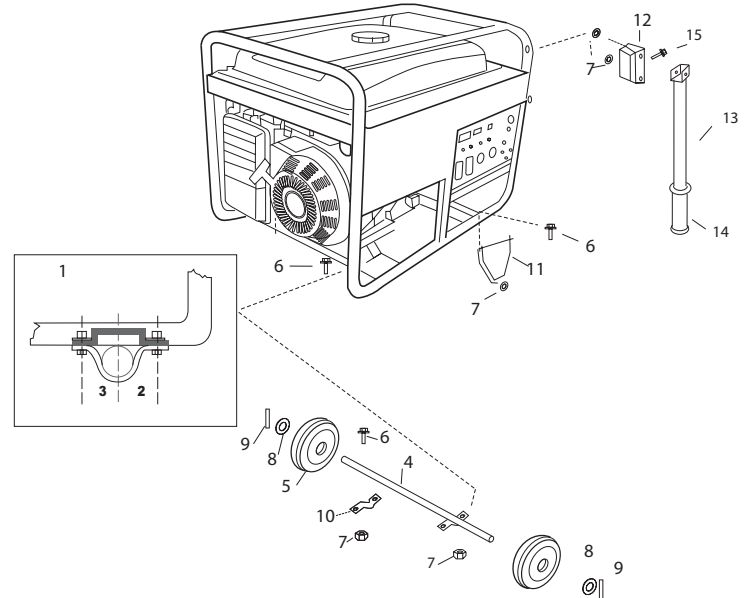

- |   |                        |                      |
|---|------------------------|----------------------|
| 1.Diagram-Mounting axle (2. Shorter end 3.Longer end) |                        |                      |
| 4.Wheel axle(1)                                       |                        |                      |
| 5.Wheel(2)  | 9. Split pin(2)        |                      |
| 6.Bolt M8X16(6)                                       | 10.Axle holder(2)      | 13.Handle(2)         |
| 7.Nut M8(8)   | 11.Stand(2)            | 14.Handles sleeve(2) |
| 8.Washer(2)   | 12.Connecting block(2) | 15.Bolt M8X40(2)     |

1

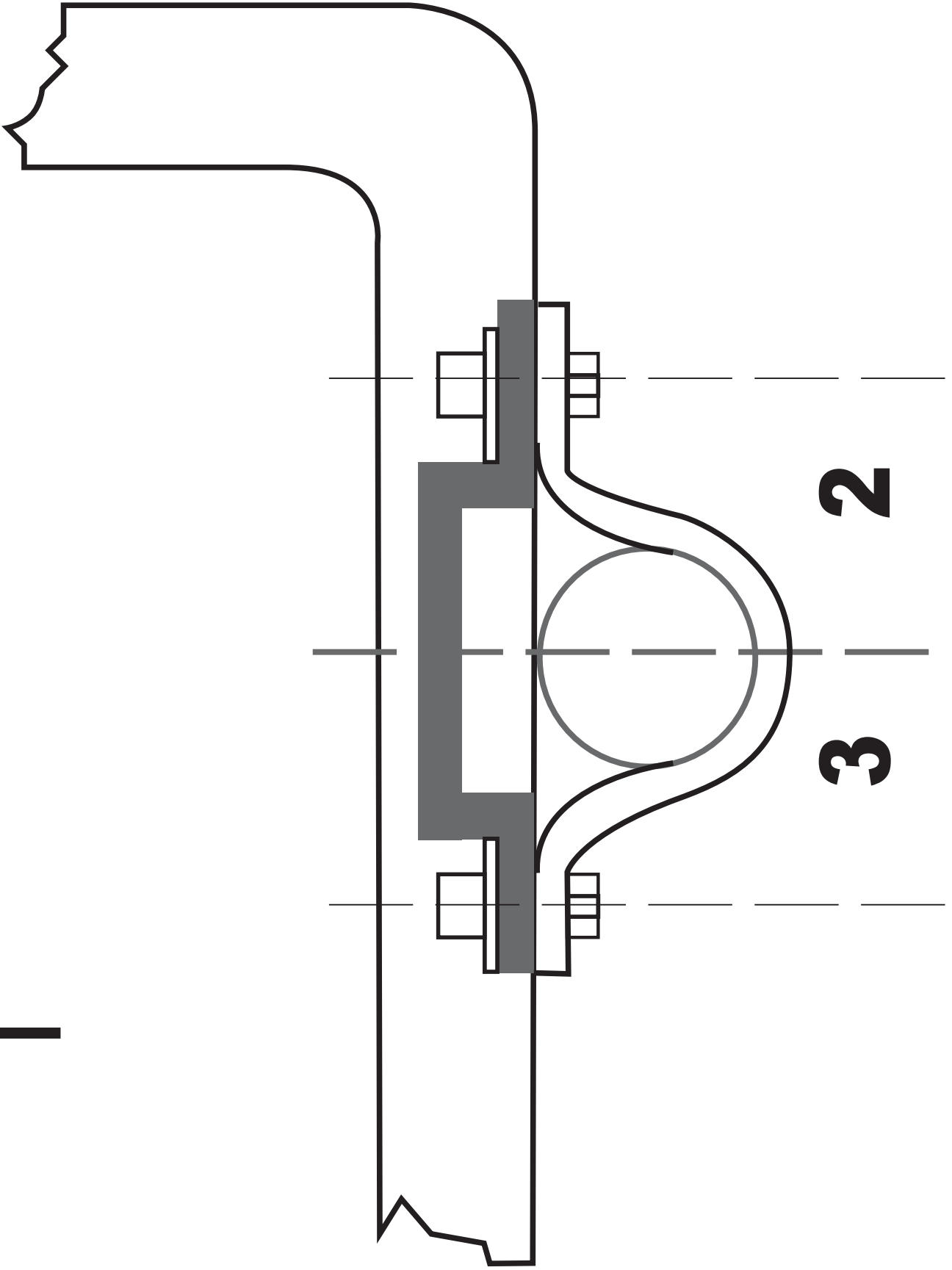

2

3

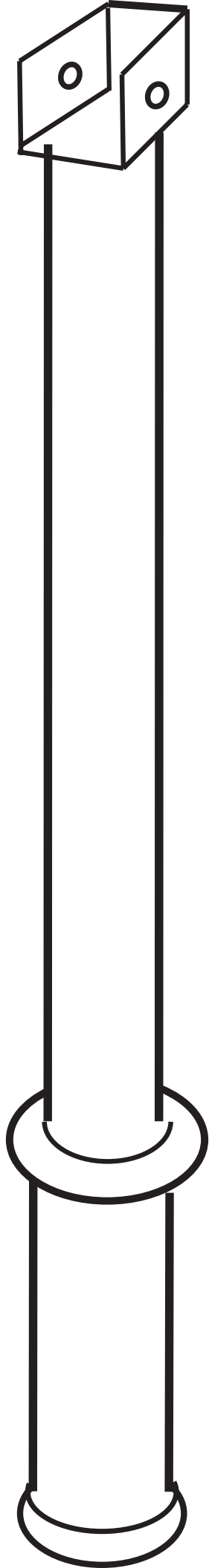

# PORTABLE GASOLINE GENERATOR

**SIERRA 5500**

## **! DANGER**

Using a generator indoors **CAN KILL YOU IN MINUTES.**

Generator exhaust contain carbon monoxide. This is a poison you cannot see or smell.

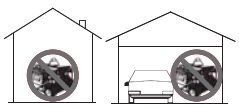

**NEVER** use inside a home or garage, **EVEN IF** doors and windows are open.

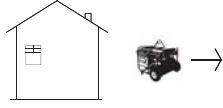

Only use **OUTSIDE** and far away from windows, doors, and vents

**Avoid other generator hazards  
READ MANUAL BEFORE USE**



**SHOCK**



**TOXIC FUME**



**EXPLOSION**



**FIRE**

# OPERATING THE GENERATOR

Generator exhaust contains carbon monoxide (CO). This is a poison you cannot see or smell. If you can smell the generator exhaust, you are breathing CO. But even if you cannot smell the exhaust, you could be breathing CO.

- **NEVER** use a generator inside homes, garages, crawlspaces, or other partly enclosed areas.
- Deadly levels of carbon monoxide can build up in these areas. Using a fan or opening windows and doors does **NOT** supply enough fresh air.
- **ONLY** use a generator outside and far away from windows, doors, and vents. These openings can pull in generator exhaust.
- Even when you use a generator correctly, CO may leak into the home. **ALWAYS** use a battery-powered or battery-backup CO alarm in the home.
- If you start to feel sick, dizzy, or weak after the generator has been running, move to fresh air **RIGHT AWAY**. See a doctor.
- You could have carbon monoxide poisoning.

## Prior operation

- Check with your local authority and local utility company before using your generator. There may be local regulations regarding generators. Additional requirements may apply to construction sites.
- Consult a qualified electrician if you have questions regarding the proper use of the generator, including any electrical devices to be connected.

**Note:** The oil should be changed after the *first five hours* of use/breaking-in of the generator. Please refer to the maintenance schedule for recommended oil changes.

## *When this generator is used to supply a building wiring system*

- Transfer switch **MUST** be used when connecting generator to a building's electrical system.
- Generator must be installed by a qualified electrician and connected to a transfer switch as a separately derived system in accordance with the National Electrical Code, NFPA 70.
- The generator shall be connected through a transfer switch that switches all conductors other than the equipment grounding conductor.

CAUTION: FOR STANDBY SERVICE, CONNECT OUTPUT OF GENERATOR TO SUITABLY RATED TRANSFER SWITCH IN ACCORDANCE WITH THE CANADIAN ELECTRICAL CODE, PART I.

### Select a safe and suitable location

- The generator should only be operated outdoors on a firm, level surface in a well ventilated area. At least five feet of clearance should be maintained from any structures or objects, and this includes space above the generator. The generator could ignite nearby materials.
- DO NOT operate the generator in wet weather or in wet conditions.
- DO NOT place or store any items on the generator. Keep children and pets away from the generator. Check the wheels before use. Hearing protection is recommended.

### Grounding

- Always ground the generator. The faceplate of your generator is marked with the following grounding symbol above the grounding terminal:



- Attach a heavy gauge copper wire (12 AWG minimum) to this terminal and link it to a copper rod driven into the ground. Consult an electrician to ensure compliance with local codes and regulations.

### Starting the Generator

- If you experience difficulty starting the generator, please refer to the TROUBLESHOOTING section in this manual.

### Warm up period

- Once the generator's engine is running, allow several minutes for the motor to stabilize before connecting any load/electrical devices.

### Connecting Equipment

- Once the generator has been allowed to run and warm up for several minutes equipment can be connected. Make sure that all cords and devices are in good condition.



SHOCK



ERLISION



FIRE

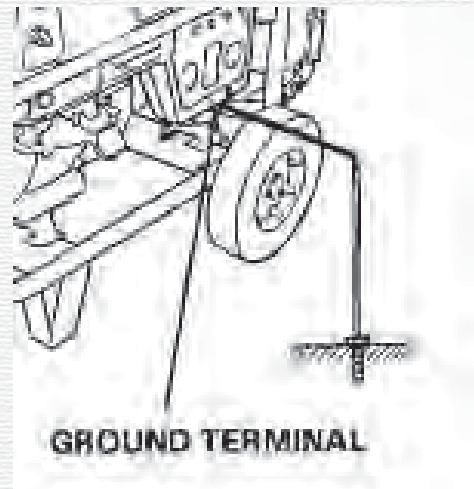

## ⚠ CAUTION

Engine oil must be added prior to starting generator, and proper oil level must be maintained. Always check dipstick to ensure proper oil level before attempting to start generator.

# PORTABLE GASOLINE GENERATOR

**SIERRA 5500**

## Starting the Generator

- 1. Make sure the AC circuit breaker is in the OFF position.

### CIRCUIT BREAKER

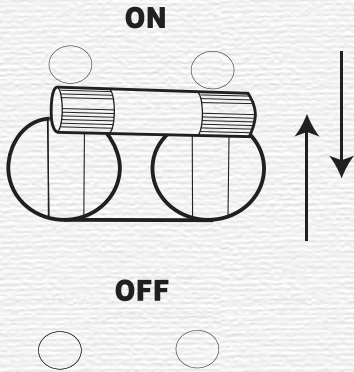

- 2. Turn the fuel valve lever to the ON position.

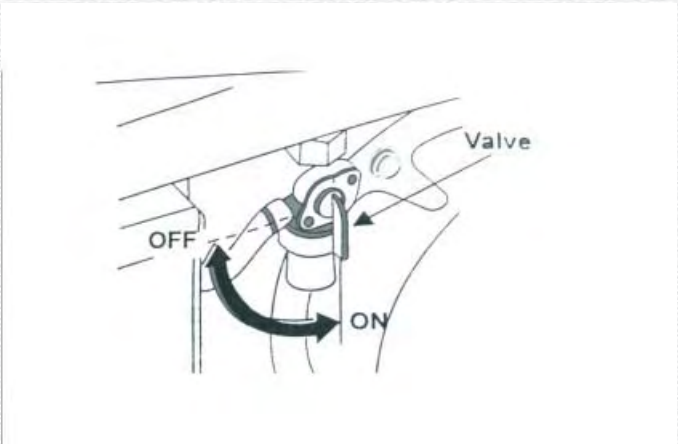

- 3. Pull choke lever out to the CLOSED position.  
**Note:** Do not use the choke lever if the engine is warm or if the air temperature is high.

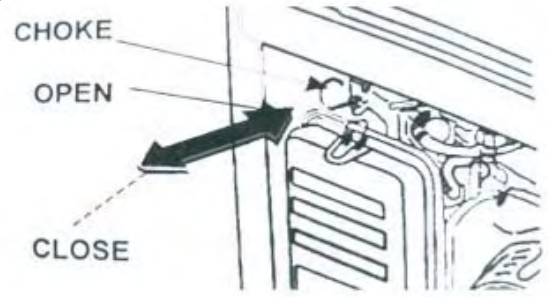

- 4. Make sure the Auto Throttle switch is OFF, or more time will be required to warm up.

### AUTO THROTTLE

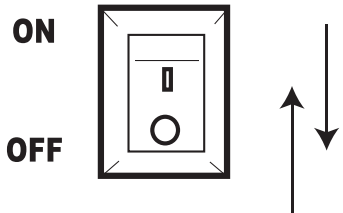

- 5. Turn the engine switch to the ON position.

### ENGINE SW

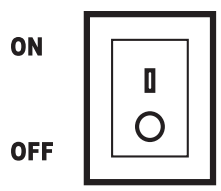

# Starting the Generator

- 6.** For Recoil Starter - Pull the Starter Grip lightly until resistances felt, then pull rapidly.

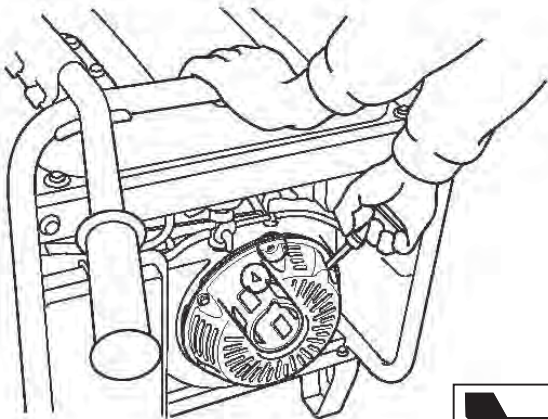
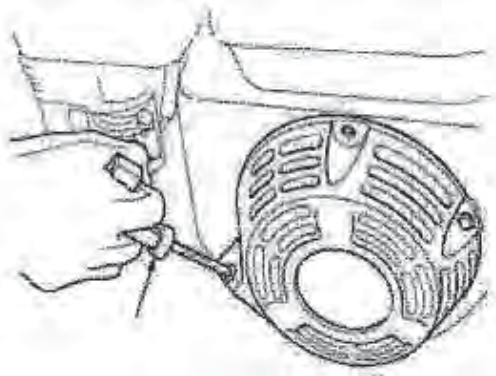

**ICBACK**

## ENGINE SW

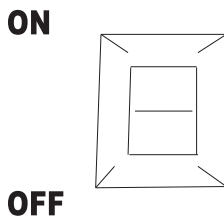

- 7.** Push the choke lever to the OPEN position as engine warms up. The choke is used to provide the proper mixture when the engine is cold. It can be opened and closed by operating the choke lever manually, Move the lever to the closed position to enrich the mixture for the cold starting.

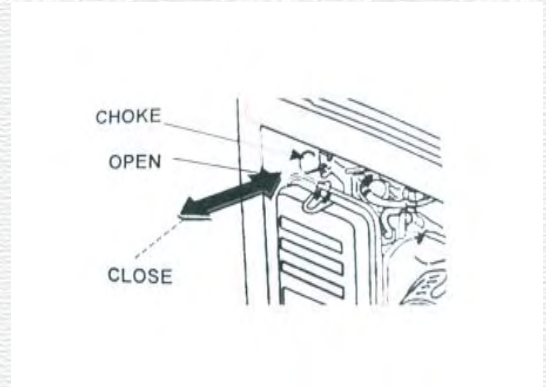

**HOT SURFACE**

- 8.** If you wish to use the Auto Throttle switch system, turn the Auto Throttle switch to the ON position after the engine has warmed up for 2 or 3 minutes. The Auto Throttle system when in the on position automatically reduces the engine speed to idle when all loads are turned off or disconnected. When the loads are turned on or reconnected, the engine resumes the rated speed. At the OFF position, the AutoThrottle system does not operate.

## AUTO THROTTLE

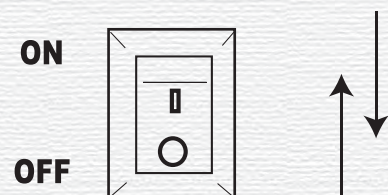

# PORTABLE GASOLINE GENERATOR

**SIERRA 5500**

## Using Electric Power

### AC Application

- 1. Check voltmeter for proper voltage.
- 2. Turn OFF the switch or switches on the electrical appliance or appliances before connecting to the generator.  
Make sure that all appliances and power cords are in good working order. Faulty appliances or power cords can create a potential for electric shock.



SHOCK

- 3. Insert the plug or plugs of the electrical appliance or appliances into the receptacle or receptacles.
- 4. Turn the AC circuit breaker to the ON position.
- 5. Turn on the ON switch or switches to the appliance or appliances that are connected to the generator.

**Note:** Do not exceed the generator's capacity. Calculate the total of wattage of all the devices you will connect to the generator. Make sure that the total wattage is below the capacity of the generator.

If the generators capacity is exceeded or "overloaded" the circuit breakers will stop the flow of electricity from the generator to the appliances.

If this happens power OFF the generator and disconnect the appliances. Wait a few minutes and then push the rest circuit breaker switch. Many electrical devices require more starting watts than running watts, a phenomenon known as "surge watts" or "starting watts". Make sure to account for this when calculating the amount of watts that will be applied.

If an appliance begins to operate abnormally or becomes sluggish or stops suddenly. Turn off the appliance immediately and disconnect the appliance from the generator

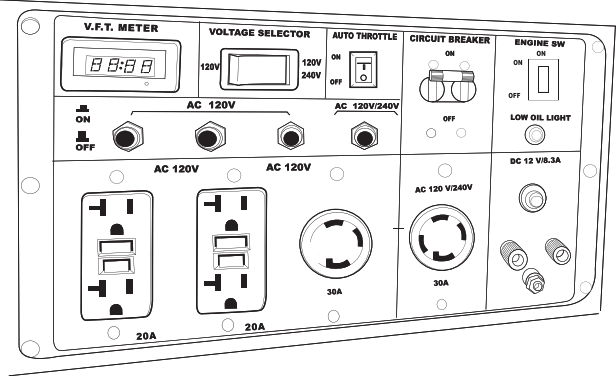

# USING ELECTRIC POWER

CONTRACTOR APPLIANCE	TYPICAL RUNNING WATTS
<b>Air Compressors</b>	
1/2 Horsepower	1,000
1 Horsepower	1,500
1 1/2 Horsepower	2,000
2 Horsepower	2,500
<b>Battery Charger</b>	3,000
<b>Bench Grinders</b>	
6 Inches	750
8 Inches	1,400
10 Inches	1,600
<b>Circular Saws</b>	
6 1/2 Inches	1,000
7 1/4 Inches	1,500
8 1/4 Inches	2,000
Drum Mixer (55 gal) (1/4 hp)	700
<b>Drills</b>	
1/4 Inch (3 amps)	300
3/8 Inch (4 amps)	450
1/2 Inch (5 amps)	600
<b>Electric Chain saws</b>	
12 Inch (1/2 hp)	1,000
14 Inch (2 hp)	1,200
Electric Cultivator (1/3 Hp)	7,000
Electric Hedge Trimmer (18 in)	400
Electric Line Trimmer (9 in)	400
Flood Lights (watts per blub)	500
Flood Polisher (16 in) (3/4 hp)	1,500
<b>Hand Drills</b>	
1/4 Inch	350
3/8 Inch	400
1/2 Inch	600
<b>Impact Wrenches</b>	
Impact Wrenches 1/2 Inch	800
Impact Wrenches 3/4 Inch	1,000
Impact Wrenches 1 Inch	1,400
<b>Saws</b>	
Worm Drive 7 1/4 Inch	2,000
Band Saw 14 Inch	1,200
<b>Table Saws</b>	
Radial 9 Inch	1,500
Radial 10 Inch	1,800
Miter Saw (10 amps)	1,200
Miter Saw (15 amps)	1,700

CONTRACTOR APPLIANCE	TYPICAL RUNNING WATTS
Wet & Dry Shop Vacuum (2Hp)	1,000
<b>Pressure Washers</b>	
5/8 Horse power	1,000
HOUSEHOLD APPLIANCE	TYPICAL RUNNING WATTS
Radio	200
Blender	200
Computer/Laptop	250
Television	300
Electric blanket	400
Freezer	500
Furnace	500
Garage door opener	600
Bread Maker	600
Dehumidifier	700
Refrigerator	700
Clothes dryer (gas)	700
Clothes dryer (Electric)	800
Sump Pump (1/2 hp)	1,000
Well Pump (1/2 hp)	1,000
Coffee Maker	1,000
Space Heater	1,000
Swamp Cooler	1,000
Toaster	1,000
Hair dryer	1,200
Iron	1,200
Dish Washer	1,200
Electric Furnace (1/2 hp)	1,400
Vacuum	1,400
Electric Range	1,500
Microwave	1,500
Washer & Dryer	2,500
Water heater	3,000
Central air Conditioner (32,000 BTU)	5,000

**Note:** Wattage values above are estimates. Always refer to the manufactures wattage requirements for the appliance you will be using.

# PORTABLE GASOLINE GENERATOR

**SIERRA 5500**

## Using Electric Power

### Full Power Switch

1. Select the voltage using the Full Power Switch (120V/240V) in accordance with the electrical appliance.
2. Operate the same as steps used in AC Application (1-5).

### DC Application

The DC terminal is used only for charging 12 volt batteries. It provides up to 12V-8.3A (100W) of maximum power.

1. Connect positive (red) terminal on the generator to the positive (+) terminal on the battery.
2. Connect the negative (black) terminal on the generator to the negative (-) terminal on the battery.
3. Both the AC and DC output can be used at the same time if the total output is within rated output of the generator.

### Note: Safety Precautions while Charging Battery

1. An explosive hydrogen gas is discharged through vent holes in the battery during charging. Do not allow sparks or open flames around the generator or battery during the charging process.
2. Electrolyte fluid can burn eyes and clothing. Be extremely careful to avoid any contact. If injured, wash the affected area immediately with large amounts of water and seek medical attention immediately.
3. When charging a large capacity battery or totally discharged battery, excessive current may force the DC breaker to turn off. In this case, use a battery charger.



FIRE



EXPLOSION



SHOCK



TOXIC FUME

# Using Electric Power

## Ground Fault Circuit Interrupter Receptacle (GFCI)

This receptacle is protected by the Ground Fault Circuit Interrupter (GFCI) for the protection. Against electrical shock.

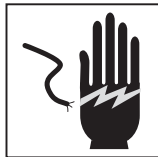

SHOCK

**Note:** Using this generator in rain, snow or in or around water can lead to electrical shock. Always keep your generator dry and away from any water source.

Perform this test monthly to insure proper operation. If use in outdoors unprotected from the weather test before each use.

## Test Button

The Rest Button should extend with a click. If the Rest Button does not extend take to an authorized GMC generator service center.

## Rest Button is used to restore power.

If the Rest Button extends during operation. Unplug all appliances from the GFCI receptacle.

## To restore power press the Reset Button

The Reset Button should be flush with the Test Button.

If the Reset Button is not flush with the Test Button take to an authorized GMC generator service center.

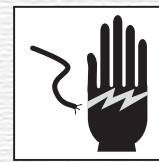

SHOCK

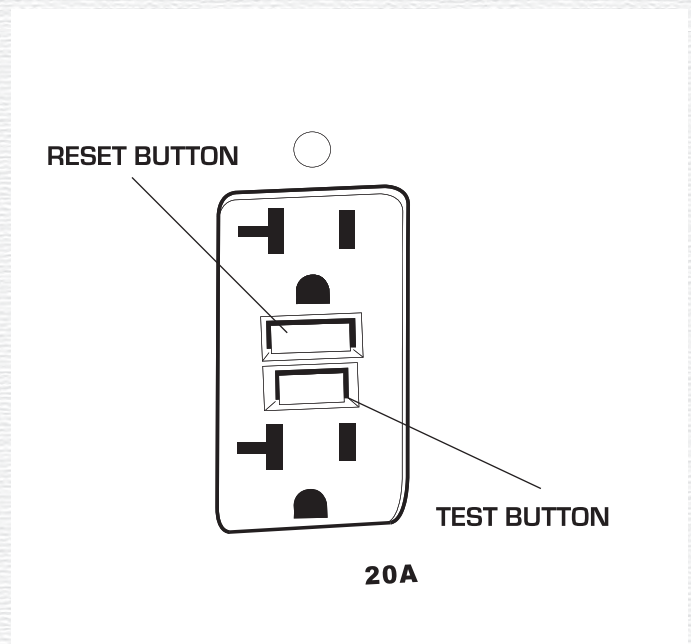

# PORTABLE GASOLINE GENERATOR

**SIERRA 5500**

## Stopping Generator

- 1. In an Emergency – Turn the engine switch to the OFF position.
- 2. In normal use:
  - A. Turn off any connected appliances and unplug any power tools
  - B. Turn the AC circuit breaker to the OFF position
  - C. Turn the Engine switch to the OFF position
  - D. Turn fuel valve lever to the CLOSED position

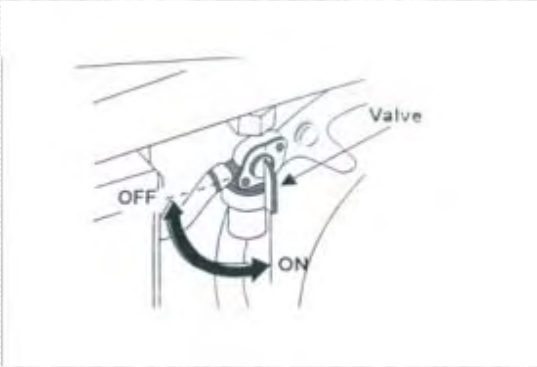
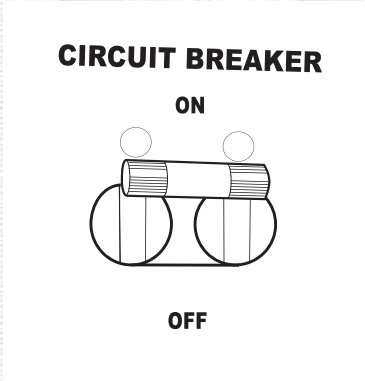
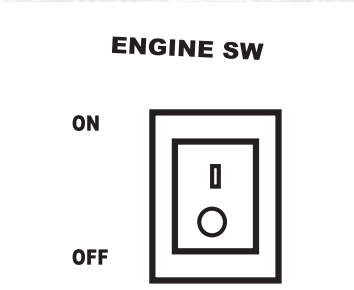

## High Altitude Operation

At high altitudes, standard carburetors air-fuel mixture will be excessively rich. Performance will decrease and fuel consumption will increase.

High altitude performance can be improved by installing a smaller diameter main fuel jet in the carburetor and then readjusting the pilot screw. If you always operate the engine at the altitudes higher than 5000 feet (1500 meters) above sea level, have an authorized GMC generator dealer perform this carburetor modification.

Even with suitable carburetor jetting, engine horsepower will decrease approximately 3.5% for each 1000 foot (300 meters) increase in altitude. The effect of altitude on horsepower will be greater than this if no carburetor modification is made.

**Note:** If the carburetor is jetted for high altitude and is used at lower altitude, performance may be reduced and overheating may seriously damage the engine due to lean air/fuel mixture.

# Maintenance

Proper maintenance is the responsibility of the Owner. Your generator requires periodic maintenance and adjustments to keep the generator in good operating condition. Refer to the Maintenance Schedule chart for specific maintenance and intervals. Please keep in mind that this maintenance schedule is for normal working conditions.

**Note:** Always turn off your generator and allow the generator to cool down before performing the maintenance. Remove the spark plug wire before attempting maintenance. This prevents the generator from starting unintentionally.



SHOCK



KICKBACK

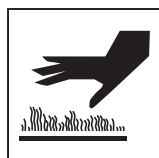

HOT SURFACE

Generators vibrate during normal use. During and after the use of the generator, inspect the generator as well as extension cords and connected power supply cords for damage resulting from vibration. Repair or replace damaged items as necessary. Do Not use plugs or cords that show signs of damage such as broken or cracked insulation or loose or damaged blades

# Emission Control System

Combustion may generate such pollutants as (CO), Nitrogen oxides, Hydrocarbons, which may contaminate the environment if large amounts of them are emitted into the air. Among them (CO) is a kind of colorless, flavorless and toxic gas. Excessive inhalation of it may make people poisoned or even dead. It is of great importance to control them in turn. To ensure the emission of your gasoline engine meets the standard on emission, the following items should come to your attention.



TOXIC FUME

<b>⚠ DANGER</b>	
<p><b>Using a generator indoors CAN KILL YOU IN MINUTES.</b></p> <p>Generator exhaust contain carbon monoxide. This is a poison you cannot see or smell.</p>	
<p><b>NEVER</b> use inside a home or garage, <b>EVEN IF</b> doors and windows are open.</p>	<p>Only use <b>OUTSIDE</b> and far away from windows, doors, and vents</p>
<p><b>Avoid other generator hazards</b> <b>READ MANUAL BEFORE USE</b></p>	

Unauthorized modification or changes to the emission control system may cause the emission higher than the legal specifications. The unauthorized modification or changes to the inlet or outlet system or to the connections for the speed governing system are not authorized and should not be done.

# PORTABLE GASOLINE GENERATOR

**SIERRA 5500**

## General Inspection Maintenance Rules

1. Make sure that all labels are present and legible
2. Check that all protective guards, handles and wheels are undamaged.
3. Verify the proper level of the engine oil.
4. Inspect the fuel line for defects.
5. Inspect the gas tank cap. Make sure it is undamaged and secured tightly. Make sure there are no spills.
6. Check that the exhaust system is in good condition and not blocked.
7. Verify that the generator is properly grounded
8. Make sure that all control panel switches are in good condition.
9. Make sure that all receptacles are in good condition.
10. Make sure all bolts and nuts are tighten down. (Check Sky Hook and Battery Cage)
11. Make sure that nothing is stored on the generator.
12. Additionally , all cords and devices should be in good condition.

## Maintenance



FIRE EXPLOSION KICKBACK



SHOCK

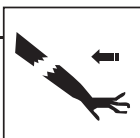

KICKBACK



TOXIC FUME

<b>⚠ DANGER</b>	
Using a generator indoors <b>CAN KILL YOU IN MINUTES.</b> Generator exhaust contain carbon monoxide. This is a poison you cannot see or smell.	
<p><b>NEVER</b> use inside a home or garage, <b>EVEN IF</b> doors and windows are open.</p>	<p>Only use <b>OUTSIDE</b> and far away from windows doors, and vents</p>
<b>Avoid other generator hazards READ MANUAL BEFORE USE</b>	

# MAINTENANCE

## Maintenance Schedule

### SERVICE FREQUENCY

ITEM	Maintenance	Each Use/ Daily	First Month Or 20 Hours Of Use	Every 3 Months Or 50 Hours Of Use	Every 6 Months Or 100 Hours Of Use	Every Year Or 200 Hours Of Use
General Inspection	See Maintenance Rules Above	X	X			
Engine Oil	Check Oil Level	X				
	Change Oil		X		X	
Air Filter	Check	X				
	Clean			X (1)		
Fuel Sediment Cup	Clean			X (1)	X	
Spark Plugs	Clean/ Replace				X	
Spark Arrestor	Clean				X	
Valve Clearance	Clean/ Adjust					X (2)
Fuel Tank & Strainer	Clean					X (2)
Fuel Line	Check/ Replace	Every 2 years ( replace if necessary) (2)				

(1). Clean more frequently when used in dusty areas.

(2). This maintenance should be preformed by an authorized service dealer.

# PORTABLE GASOLINE GENERATOR

**SIERRA 5500**

## Maintenance

### Engine Oil

#### Checking Oil Level

1. Have your generator on a flat, level surface.  
**Note:** Stop generator from running. Allow to completely cool.



HOT SURFACE

2. Remove the oil filter cap and wipe the dipstick clean with a clean cloth.
3. Check the oil level by inserting the dipstick in the filter neck without screwing it in. If the level is below the lower level line, add the recommended oil until the level reaches the upper mark on the dipstick.
4. Oil capacity to the upper level line 1.1 [L] [1.2[qt]]

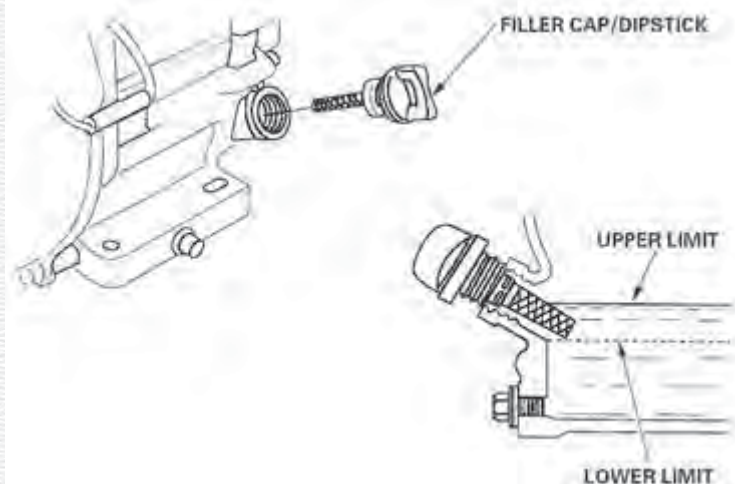

### Changing Engine Oil

1. Have your generator on a flat, level surface.
2. Drain the oil while the engine is warm to assure rapid and complete draining.
3. Place a oil pan or other suitable container for the oil underneath the generator oil drain plug.
4. Remove the drain plug and filter cap and drain oil into the oil pan or other suitable container.

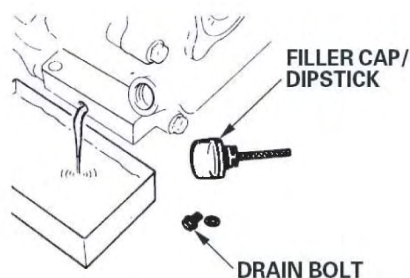

5. Using a clean cloth wipe off any dirt from the drain plug and filter cap than retighten the drain plug.
6. Refill with the recommended oil (see page 16) and check the oil level (see below)
7. Oil capacity to the upper level line 1.1 [L] [1.2 [qt]]

UPPER LEVEL



**Caution:** Frequent or prolonged contact with engine oil may cause skin cancer. Thoroughly wash your hands with soap and water as soon as possible after handling oil.

**Note:** Dispose of used motor oil according to guidelines established by the local or state government. It is recommended to put the oil in a sealed container and taken to a service station for reclamation. Do Not dispose of oil in the trash, drain or the ground due to contamination.

# Maintenance

## Air Filter Cleaning

A dirty air filter will restrict air flow to the carburetor. To prevent poor engine performance or damage due to a carburetor malfunction, service the air filter regularly.

Refer to the Maintenance Schedule (page 29) for regular service intervals.

**Note:** Never run a generator without the air filter. Do not clean the air filter using gasoline or any cleaning agent of a low fire point.



FIRE



EXPLOSION

1. Stop engine from running
2. Remove the air filter cover by removing the two clips on the cover.
3. Remove the air filter.
4. Wash the foam air filter in household soap and warm water.
5. Rinse thoroughly and dry completely.
6. Soak the air filter in clean engine oil and squeeze out the excess oil.  
**Note:** The engine will smoke during start-up if too much oil is left in the air filter
7. Reinstall the air filter and replace the air filter cover and clips.

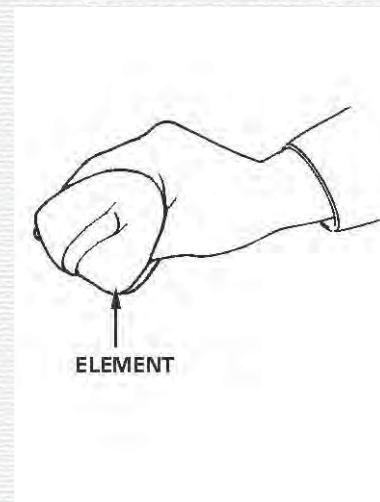

# PORTABLE GASOLINE GENERATOR

**SIERRA 5500**

## Maintenance

### Sediment Cup Cleaning

The sediment cup prevents dirt and water that may be in the fuel tank from entering the carburetor. Refer to the Maintenance Schedule (page 29) for regular service intervals.

- 1.** Stop engine.
- 2.** Have your generator on a flat, level surface.
- 3.** Turn the fuel valve lever to the CLOSED position.
- 4.** Remove the sediment cup.
- 5.** Clean the cup and screen thoroughly with soap and water.
- 6.** Use a clean cloth and wipe all pieces dry.
- 7.** Reinstall the sediment cup making sure the O-ring is in place.
- 8.** Turn the fuel valve lever to the OPEN position.
- 9.** Check for fuel leaks.

**Note:** Make sure the area is dry before starting

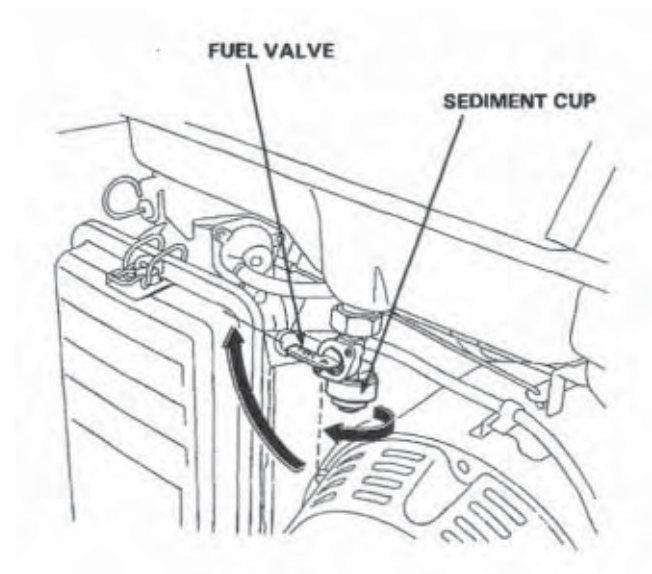

# Maintenance

## Spark Plug Service

Recommended spark plugs: **F7RTC**

To ensure proper engine operation, spark plug must be properly gapped and free of deposits. Refer to the Maintenance Schedule (page 29) for regular service intervals.

**Note:** If engine has been running, the muffler will be very Hot. Do Not touch the muffler.



HOT SURFACE



TOXIC FUME

1. Stop engine.
2. Have your generator on a flat, level surface.
3. Remove the spark plug cap. Clean any dirt or debris from around the spark plug base.
4. Use a 13/16" spark plug socket wrench and loosen and remove the spark plug.

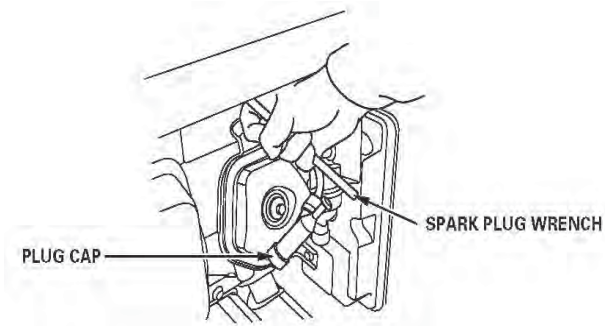

5. Inspect the spark plug. If the insulator is cracked or chipped discard plug and replace with a new spark plug.
6. If the spark plug is in good condition clean the spark plug with a wire brush.

7. Measure the plug gap with a feeler gauge. The correct gap should be 0.70 – 0.80 mm (0.028 – 0.031 in).

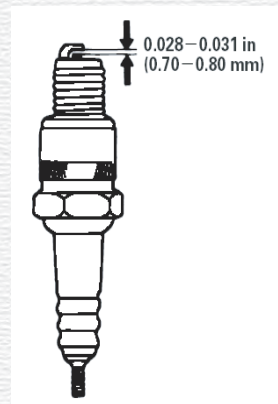

8. If the gap is incorrect. Be careful when bending the side electrode.
9. Inspect that the spark plug washer is in good condition.
10. Reinstall the spark plug by hand. This will prevent cross-threading.
11. After the spark plug is seated, tighten with spark plug wrench to compress the washer.
  - A. When reinstalling a used spark plug, tighten 1/8 – 1/4 turn after the spark plug seats to compress the washer
  - B. When installing a new spark plug, tighten 1/2 turn after the spark plug seats to compress the washer

**Note:** The spark plug must be securely tightened. An improperly tightened spark plug can become very hot and could damage the engine. Never use spark plugs which have an improper heat range. Use only recommended spark plugs or equivalent

# PORTABLE GASOLINE GENERATOR

## SIERRA 5500

### Maintenance

#### Spark Arrestor Maintenance

The generator muffler is equipped with a spark arrestor which must be cleaned. Refer to the Maintenance Schedule (page 29) for regular service intervals.

1. Stop engine.
2. Have your generator on a flat, level surface.
3. Loosen the screw by the exhaust port of the muffler and remove the spark arrestor.

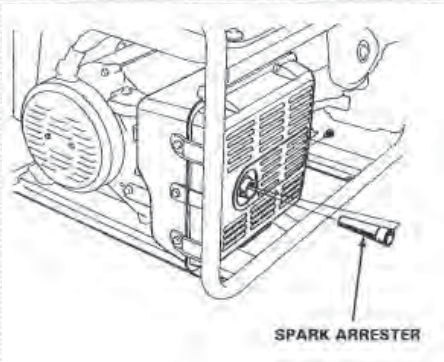

HOT SURFACE



TOXIC FUME

4. Use a brush and remove debris or deposits from the screen.
5. Inspect the screen for any breaks or tears. If so replace screen.
6. Reinstall the spark plug arrestor.

#### Cleaning Exterior of Generator

1. Do Not spray the generator with water or a garden hose.
2. Wipe surface with a damp cloth or use a soft brush to remove dirt or dust.
3. Cover generator with a clean cover.

**Note:** Never cover generator when running or when hot. Cover only after the generator is cool.



HOT SURFACE



FIRE

# Transporting/Storage

## Transporting

1. Turn the engine switch to the off position.
2. Turn the fuel valve lever to the CLOSED position
3. Keep the generator level to prevent fuel spillage.



FIRE



EXPLOSION

## Storing

Before storing for generator for extended period of time:

1. Be sure the storage area is free of excessive humidity and dust.
2. Turn fuel valve lever to the CLOSED position.
3. Remove the sediment cup. [refer to page 23]
4. Turn the fuel valve lever to the OPEN position.
5. Drain fuel into a suitable container for gasoline.
6. Replace the sediment cup and tighten securely.
7. Drain the carburetor by loosening the drain screw. Drain gasoline into a suitable container.

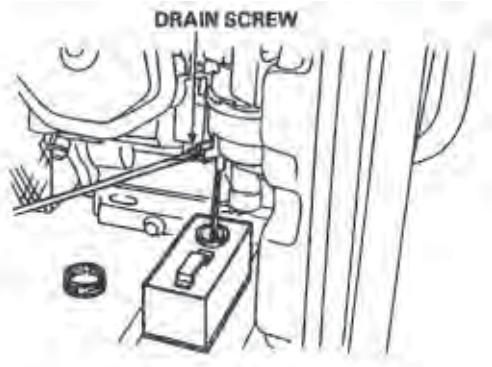

8. Change the engine oil. [ refer to page 30]
9. Remove the spark plug cap and pour a tablespoon of clean engine oil into the cylinder. [refer to page 33]  
Put a clean cloth over the spark plug hole. Crank the engine several revolutions to distribute the oil. Reinstall the spark plug.
10. Slowly pull the starter grip until resistance is felt. At this point, the piston is coming up on its compression stroke and both the intake and exhaust valves are closed. Storing the engine in this position will help to protect it from internal corrosion



KICKBACK

11. Cover the engine to prevent dust from getting in.

# PORTABLE GASOLINE GENERATOR

**SIERRA 5500**

## TROUBLESHOOTING

PROBLEM	POSSIBLE CAUSE	
Engine does not start	No fuel Low oil level Engine switch is not ON Fuel valve is not open Spark plug cable is loose or detached  Spark plug is defective Load is attached Uneven surface	Add fuel Add oil Turn engine switch ON Open fuel valve Connect spark plug cable tightly Replace spark plug Remove load Place generator on a level surface
Unrestrained/rapid engine speed	Defective governor	Contact authorized service center
Generator lacks sufficient power	Generator is overloaded Poor ventilation  Clogged/dirty air filter	Remove overload Operate generator in a well ventilated area Clean or replace air filter
Generator is overheating	Generator is overloaded Poor ventilation	Remove overload Operate generator in a well ventilated area
No AC output	Tripped circuit breaker Cord is not properly connected	Disconnect load and reset breaker Connect cord properly
	Wiring is loose Faulty device	Tighten connections Replace device
No DC output	Tripped circuit breaker	Disconnect load and reset breaker
Exhaust is black	Choke position closed Dirty air filter Incorrect fuel	Open choke Clean or replace filter Use correct fuel
Circuit breaker trips repeatedly	Generator is overloaded Faulty cord or device	Remove overload Replace cord or device
Engine stops	Out of fuel Low oil Uneven surface  Poor ventilation	Add fuel Add oil Place generator on a level surface Operate generator in a well ventilated area



FIRE



EXPLOSION



KICKBACK



HOT SURFACE



SHOCK

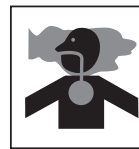

TOXIC FUME

**⚠ DANGER**

Using a generator indoors **CAN KILL YOU IN MINUTES.**  
Generator exhaust contain carbon monoxide. This is a poison you cannot see or smell.

NEVER use inside a home or garage, <b>EVEN IF</b> doors and windows are open.	Only use <b>OUTSIDE</b> and far away from windows doors, and vents

Avoid other generator hazards  
READ MANUAL BEFORE USE

# WIRING DIAGRAM

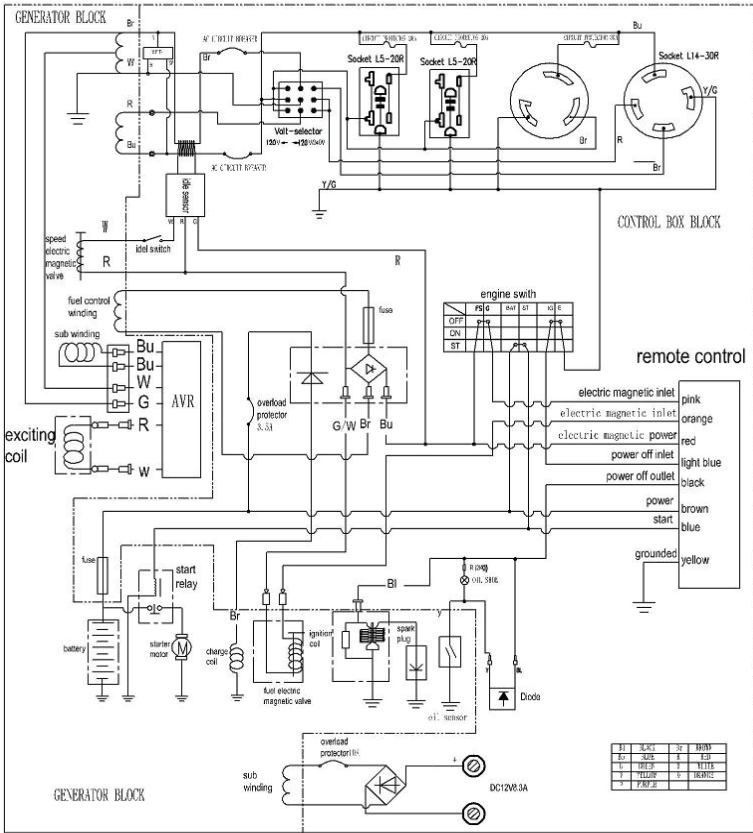

# SPECIFICATIONS

<b>Generator</b>	
Model	SIERRA 5500
Rated Output	5000 Watts
Maximum Output	5500 Watts
Frequency	60 Hz
Voltage	120/240 Volts
Rated Amps 120/240	42/21 amps
<b>Engine</b>	
Engine Type	Subaru - Robin - EH36
Horsepower	11.5 hp
Engine Speed (RPM)	3600 rpm
Displacement	404 cc
Compression Ratio	8.3:1
Fuel	Gasoline
Cooling System	Forced Air
Fuel Tank Capacity/Run time	7 Gal. / 10 hrs @50% load
Engine Oil Capacity	1.1L (1.2 qt)
Spark Plug Type	F7RTCJ
<b>Features</b>	
Starting: Remote or Electric or Recoil	Recoil
Automatic Idle Control	Yes
Oil Alarm	Yes
Digital Voltage, Frequency & Hour Meter	Digital Voltage, Frequency & Hour Meter
Voltage Power Selection Switch 120/240	Yes
Ground Fault Circuit Interrupter (G.F.C.I.)	Yes
Sky hook	Yes
Fuel Gauge	Yes
Spark Arrestor	Yes
Alternator	Brush
<b>Dimensions</b>	
Length	32.8 inches / 835 mm
Width	28.9 inches / 735 mm
Height	33.0 inches / 838 mm
Dry Weight	200 lbs/ 91 kg
Tires	10 inch
Battery Included	N/A
Comes complete with	2 Wheels, 2 Stands, 2 Handles, 1 Skyhook

# PORTABLE GASOLINE GENERATOR

**SIERRA 5500**

## California Air Tools Inc. Limited Warranty

This warranty is limited to the GMC Generators distributed by California Air Tools Inc.  
675 Anita Street, Suite C3  
Chula Vista California 91911

### **Limited Warranty**

California Air Tools Inc. Will repair or replace, free of charge, to the original retail customer whom purchased a GMC Generator from an authorized dealer, distributor or distributor's dealer in North America.

This warranty does not transfer to subsequent owners.

California Air Tools Inc. will repair or replace, at its option, any parts of the portable generator that are proven by an authorized service center to be defective in material or workmanship under normal use during the applicable warranty time period as stated below. This limited warranty covers the cost of the replacement parts and labor for all defects when installed by authorized service center. Transportation charges are the responsibility of the customer. Any part replaced under warranty becomes the property of California Air Tools Inc.

All parts replaced under warranty will be considered as part of original product, and any warranty on those parts will expire coincident with the original product warranty.

### **Limited Warranty Periods**

Non- commercial / Non- rental (personal use by a retail customer):	2 years parts and labor
Commercial / Rental (usage for income, business use):	2 years parts and labor (Engine only)
	2 years other components

The limited warranty period begins on the date of retail purchase by the original purchaser.

# California Air Tools Inc. Limited Warranty

## **Disclaimers, Limitations of Remedies & Exclusions**

This warranty gives you specific legal right, and you may also have other rights which may vary from State to State.

### **Disclaimer of other Warranties**

To the fullest extent permitted by applicable law, this limited warranty is exclusive and expressly in lieu of any and all other warranties, including, without limitation, any implied warranties of merchantability or fitness for a particular purpose or any other implied warranties that may arise from the course of dealing or usage of the trade. California Air Tools Inc. hereby disclaims and excludes all other warranties.

To the extent that California Air Tools Inc. products are consumer products under applicable federal and state law with respect to any customer, the duration of any implied warranties (including, but not limited to implied warranties of merchantability or fitness for a particular purpose) are limited to the shortest duration permitted by applicable law or the Limited Warranty period provided herein, whichever is longer.

### **Limitations of Remedies**

California Air Tools Inc. shall not be liable to customer, or anyone claiming under customer, for any other obligations or liabilities, including, but not limited to, obligations or liabilities arising out of breach of contract or warranty, negligence or other tort or any theory of strict liability, with respect to the generator or California Air Tools Inc. acts or omissions or otherwise. To the fullest extent permitted by applicable law California Air Tools Inc. shall not in any event be liable for incidental, compensatory, punitive, consequential, indirect, special or other damages, including but not limited to loss of use, loss of income, loss of time, loss of sales, injury to personal property, or liability customer incurs with respect to any other person, or any other type or form of consequential damage or economic loss.

# PORTABLE GASOLINE GENERATOR

**SIERRA 5500**

## California Air Tools Inc. Limited Warranty

### Exclusions

In addition to the foregoing disclaimers, limitations and terms, this limited warranty shall not apply to and does not cover accessories, nor does it cover products that are in anyway subject to:

1. Improper setup, installation or storage.
2. Lack of proper maintenance and service.
3. Accident, damage, abuse or misuse.
4. Abnormal operating conditions or applications.
5. Repair or modification by customer or any third party without written consent of California Air Tools Inc.
6. Use under operating conditions or in applications not made to or contemplated by California Air Tools Inc.
7. Normal wear.
8. Fuel contamination or deterioration.
9. Acts of God.

The application of these exclusions will be determined at California Air Tools Inc. sole discretion.

### Registration

Warranty registration with California Air Tools Inc./GMC Generators is required on all products. You can mail the enclosed registration form or fill out on line at [www.GMCGENERATORS.com](http://www.GMCGENERATORS.com) Warranty is also available by keeping and showing your original receipt from the date of purchase to an Authorized GMC Generator service center.

### Service

Do not return your generator to the place of purchase or any GMC car/ truck Dealership. For all customer service inquiries call. 1-866-409-4581 or visit [www.GMCGENERATORS.COM](http://www.GMCGENERATORS.COM)